



## Product Specification

**Customer:** \_\_\_\_\_

**Model Name:**           H040HWQ40I3509-CT1          

**Date:**   A0  

**Version:**   2023.02.28  

**Preliminary Specification**

**Final Specification**

### For Customer's Acceptance

Approved by	Comment

Approved by	Reviewed by	Prepared by





## TABLE of CONTENTS

<b>1. GENERAL INFORMATION.....</b>	<b>4</b>
1.1 Features.....	4
1.2 Mechanical Specification.....	4
<b>2. ABSOLUTE MAXIMUM RATINGS.....</b>	<b>5</b>
<b>3. MECHANICAL DRAWING.....</b>	<b>6</b>
<b>4. I/O CONNECTION &amp; BLOCK DIAGRAM.....</b>	<b>7</b>
4.1 I/O Connection.....	7
4.2 Block Diagram.....	8
<b>5. ELECTRICAL CHARACTERISTICS.....</b>	<b>9</b>
5.1 TFT-LCD Panel Driving Section.....	9
5.2 Back Light Driving Section.....	9
5.3 Power On/Off Sequence.....	10
5.4 Timing Characteristics.....	12
5.5 Timing Diagram.....	12
<b>6. OPTICAL CHARACTERISTICS.....</b>	<b>13-14</b>
<b>7. RELIABILITY.....</b>	<b>16</b>
<b>8. PACKAGE DRAWING.....</b>	<b>17</b>



## 1. GENERAL INFORMATION

### 1.1 Features

- 1) Pixel Arrangement: RGB Vertical Stripe
- 2) Interface Mode: 3SPI-RGB 18bits
- 3) Driver IC: GC9503V TP IC: FT6336U
- 4) Operation Temperature: -20~70°C
- 5) Storage Temperature: -30~80°C
- 6) Backlight Type: White LED
- 7) Display mode: Normally Black,
- 8) Pixel Density: 169 PPI
- 9) LED life time: 30,000 Hours

### 1.2 Mechanical Specification

Item 项目	Specification 规格	Unit 单位	Remark 备注
<b>Pixel Driving element</b>	A-Si TFT	-	
<b>Screen Size</b>	4.0	Inch	Diagonal
<b>Resolution</b>	480(W)*3(RGB)*480(H)	Dots	
<b>Interface</b>	3SPI_RGB 18bits	-	40PIN
<b>Module Power Consumption</b>	1.1	Watt	Typ.
<b>VActive VArea</b>	72.36(W)*70.68(H)	mm	
<b>CTP_Pixel pitch (W*H)</b>	0.1497(W)*0.1462(H)	mm	
<b>Module Size (W*H*D)</b>	84(W)*84(H)*3.22(D)	mm	
<b>Luminance(LCM+CTP)</b>	300	cd/m <sup>2</sup>	Typ.
<b>Viewing Direction</b>	All	O'clock	-
<b>Display Color</b>	262K	Colors	18bits



## 2. ABSOLUTE MAXIMUM RATINGS

Item 项目	Symbol 符号	Min. 最小值	Max. 最大值	Unit 单位	Remark 备注
Power supply voltage	VDD	-0.3	4.6	V	
Power supply voltage	-	-	-	V	
LED forward current	I <sub>F</sub>	-0.001	30	mA	For each led,Note1
LED Reverse Voltage	V <sub>R</sub>	-	5	V	For each led,Note1
Operating temperature	T <sub>op</sub>	-20	70	°C	Note1,2
Storage temperature	T <sub>st</sub>	-30	80	°C	Note1,2
Humidity	H <sub>st</sub>	10	90	%RH	Note1,3

(Ta=+25°C,GND=0V)

Note1:If the module exceeds the absolute maximum ratings, it may be damaged permanently. Also if the module operates with the absolute maximum ratings for a long time, the reliability may drop.

Note2: In case of temperature below 0°C, the response time of liquid crystal (LC) becomes slower and the color of panel darker than normal one.

Note3: Temp. ≤ 60°C , 90% RH MAX.

Temp. >60°C , Absolute humidity shall be less than 90% RH.

## 3. MECHANICAL DRAWING

# 正面

# 侧面

# 背面

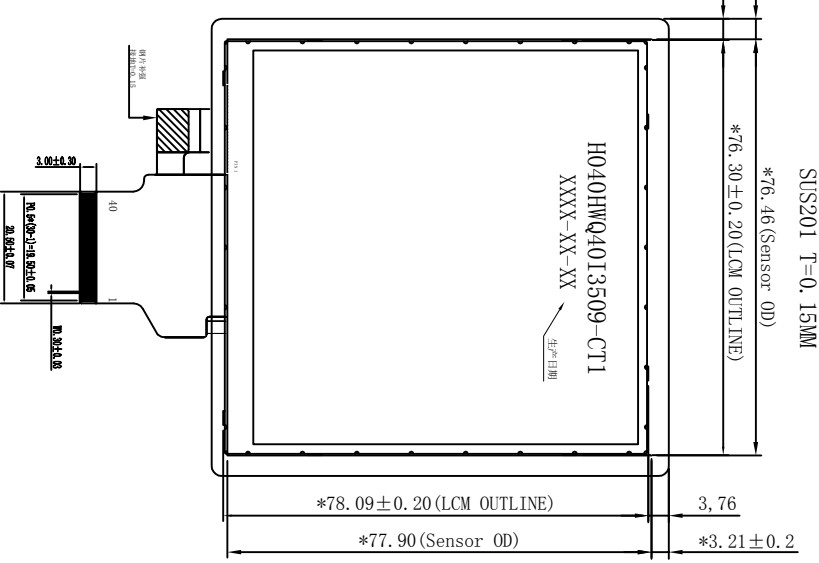
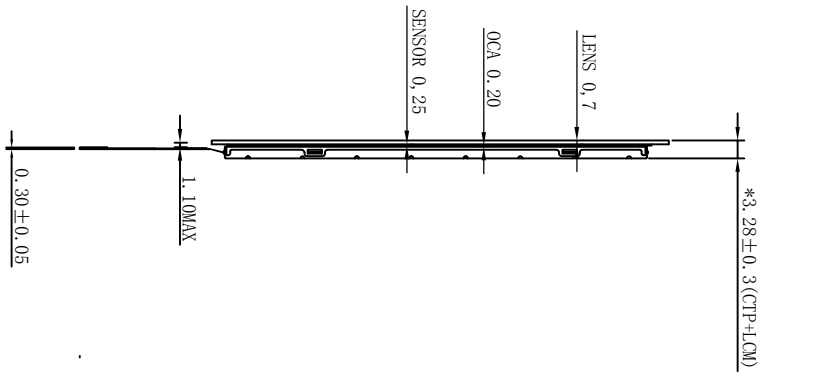
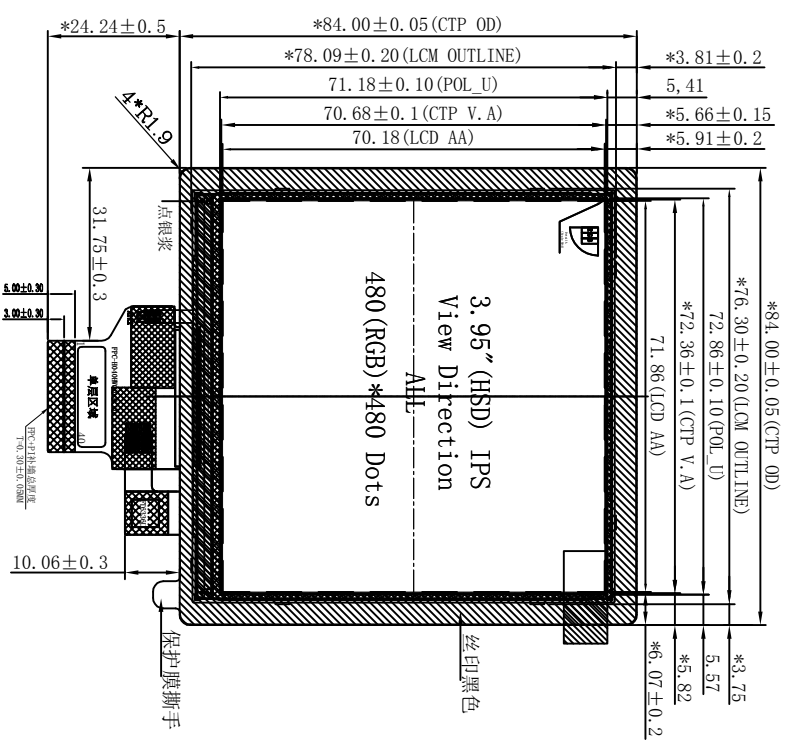

- LCM NOTES:
1. DISPLAY TYPE: 3.95 INCH TFT
  2. BACKLIGHT: 8 CHIP WHITE LED, IN PARALLEL
  3. OPERATING TEMP:  $-20^{\circ}\text{C} \sim +70^{\circ}\text{C}$
  4. STORAGE TEMP:  $-30^{\circ}\text{C} \sim +80^{\circ}\text{C}$
  5. RESOLUTION: 480xRGBx480
  6. LCD IC: GC9503CV
  7. " ( ) " Reference dimension. "\*" critical dimension
  8. RoHS Compliant
- CTP 技术要求:
1. 结构: G+G;
  2. 应用方式: 单点+手势;
  3. 应用方案: FT6338U
  4. 透光率:  $\geq 85\%$ ;
  5. 表面硬度: 6H; 戴以CG透明子强化
  6. 跌落: 6枚钢球30cm, 中心点一次不做碎;
  7. 工作环境:  $-20^{\circ}\text{C} \sim +70^{\circ}\text{C}$ ,  $\leq 90\text{RH}$ ;
  8. 储存环境:  $-30^{\circ}\text{C} \sim +80^{\circ}\text{C}$ ,  $\leq 90\text{RH}$ ;
  9. 未注公差  $\pm 0.2\text{mm}$ ;
  10. 产品符合RoHS;

Display Type	TFT
Viewing Angle	NORMALLY WHITE, TRANSMISSIVE
LCD Driver IC	GC9503CV
Logic Voltage	VDD=2.8V
Operation Temperature	$-20^{\circ}\text{C}$ TO $70^{\circ}\text{C}$
Storage Temperature	$-30^{\circ}\text{C}$ TO $80^{\circ}\text{C}$
Interface	RGB INTERFACE
Backlight	8-LED WHITE 40MA/12.8V
Surface Luminance (LCM+CTP)	300cd/m <sup>2</sup> (typ)
White X/Y	X:--- Y:---

INTERFACE	MIPi Interface
	FPC Connector
VIEWING DIRECTION	ALL
	Gray Scale
DIRECTION	FREE

MODEL NAME	TFT Display Module	PART NO.	H040HWQ4013509-CT1
	DWN		REV. SHEET OF
CHMD		TOLERANCE UNLESS	$\pm 0.1$
PROJECTION	3RD ANGLE	SPECIFIED	UNIT
			SCALE
			1:1

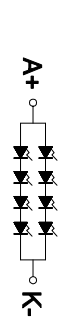

FPC 展开出货

LCM PIN	SYMBLE
1	LED1
2	LED2
3	LED3
4	GND
5	VCL
6	RESET
7	NC
8	NC
9	SDA
10	SCK
11	CS
12	PLK
13	DE
14	VSYNC
15	Hsync
16-21	BD <sup>+</sup> /B5
22-27	G0/G5
28-33	R0/R6
34	GND
35	TP+INT
36	TP-SDA
37	TP-SCL
38	TP-RST
39	TP-VCI
40	GND



## 4. I/O CONNECTION & BLOCK DIAGRAM

### 4.1 I/O Connection

Pin No. 序号	Symbol 符号	I/O	Description 描述
1	LEDA	P	Power supply for backlight anode
2	LEDK1	P	Power supply for backlight cathode
3	LEDK2	P	Power supply for backlight cathode
4	GND	P	Power Ground
5	VCI	P	Power supply to the internal logic power regulator( 3.3V)
6	RESET	I	The signal will reset the LCM, Signal is active low.
7-8	NC	-	No conneted
9	SDA	I/O	Serial in/out signal, for initial RGB I/F。
10	SCK	I	serial interface clock, for initial RGB I/F。
11	CS	I	Chip select input pin ("Low" enable), for initial RGB I/F。
12	PCLK	I	Pixel clock input pin, Negative polarity
13	DE	I	Data input enable. Display access is enabled when DE is "H"
14	VSYNC	I	Vorizontal sync signal, Negative polarity
15	HSYNC	I	Hertical sync signal, Negative polarity
16-21	B0-B5	I	Blue data input.
22-27	G0-G5	I	Green data input.
28-33	R0-R5	I	Red data input.
34	GND	P	Power Ground
35	TP_INT	O	Interrupt signals for TP
36	TP_SDA	I/O	I2C data signals for TP
37	TP_SCL	I	I2C clock signals for TP
38	TP_RST	I	The signal will reset the TP, Signal is active low
34	TP_VCI	P	TP_VDD(2.8V) Power Supply for TP
40	GND	P	Power Ground



## 4.2 Block Diagram

### MCU and Display Module Interface Configuration

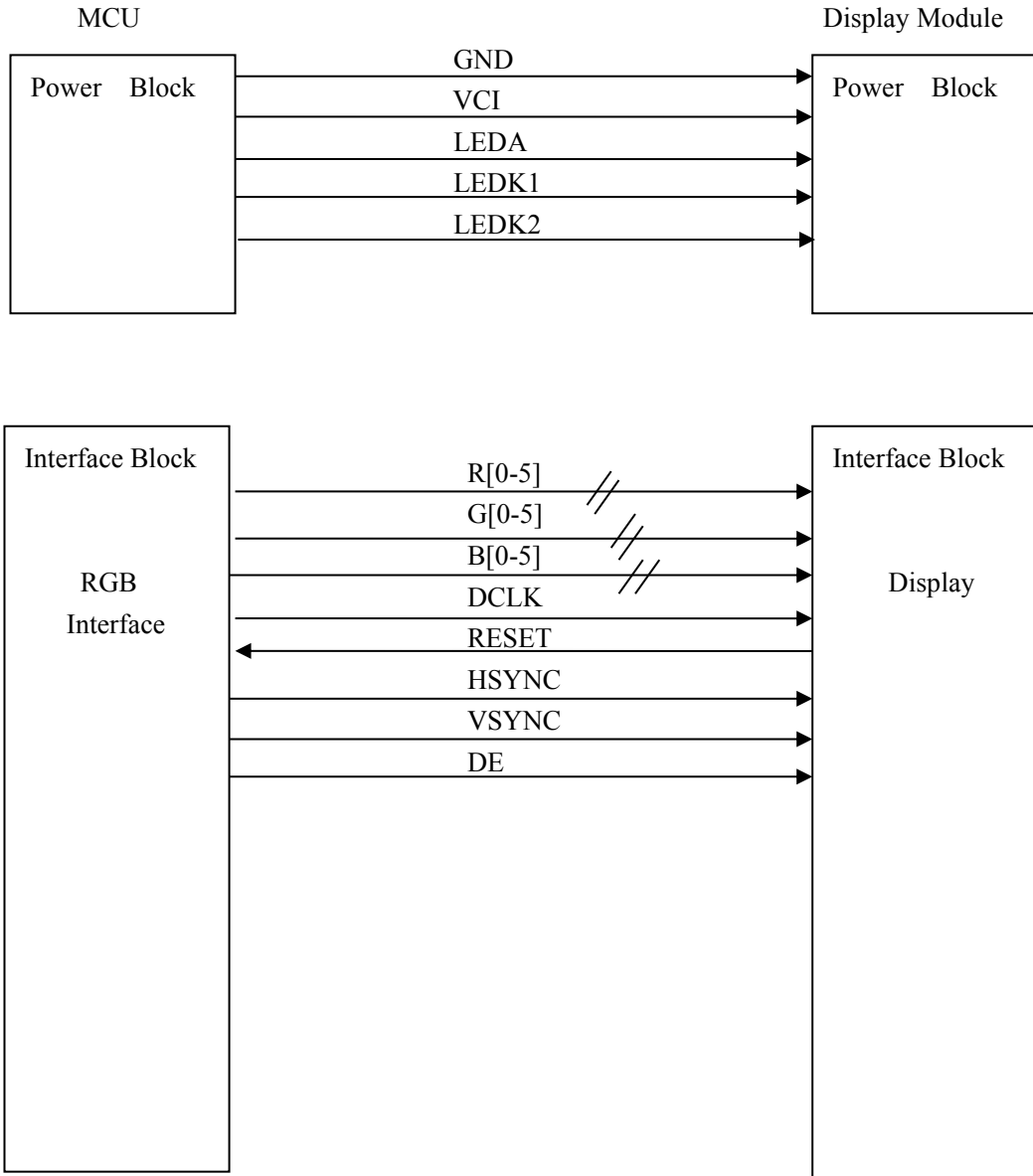



## 5. ELECTRICAL CHARACTERISTICS

### 5.1 TFT-LCD Panel Driving Section

Item 项目	Symbol 符号	Min. 最小值	Typ. 典型值	Max. 最大值	Unit 单位	Remark 备注
Power Supply Voltage	VCI	2.8	3.3	3.3	V	
Power Supply Voltage	-	-	-	-	V	
Power Supply Current	IVDD	-	30	-	mA	Note1
Logic Input High Voltage	V <sub>IH</sub>	0.7VCI	-	VCI	V	-
Logic Input Low Voltage	V <sub>IL</sub>	0	-	0.3VCI	V	-
Panel Power Consumption	P <sub>VDD</sub>	-	0.099	-	Watt	Note1
Module Power Consumption	P <sub>LCM</sub>	-	1.1	-	Watt	Note1,2

(Ta=+25°C,GND=0V)

Note1: Measurement Conditions (Video Mode): Full Screen Red Pattern, VDD=3.3V, 60Hz Refresh.

Note2: P<sub>LCM</sub> = P<sub>VDD</sub> + P<sub>BL</sub>, About P<sub>BL</sub> information, inference to 5.2 Back Light Driving Section.

### 5.2 Back Light Driving Section

Item 项目	Symbol 符号	Min. 最小值	Typ. 典型值	Max. 最大值	Unit 单位	Remark 备注
Forward Voltage	V <sub>F</sub>	-	12.8		V	Note1
Forward Current	I <sub>F</sub>	-	40	-	mA	Note1
Backlight Power consumption	P <sub>BL</sub>	-	0.51	-	Watt	Note1
LED life time	-	30000	-	-	Hrs	Note2
LED Quantity			8		PCS	

(Ta=+25°C,GND=0V)

Note1: The LED driving condition is defined for each LED module (5 LED Serial, 2 LED Parallel).

For each LED : I<sub>F</sub>=20mA, V<sub>F</sub>=3.2V(Typ.)/3.4V(Max.), Ta=25°C。

Note2: The “LED life time” is defined as the module brightness decrease to 50% of original brightness at I<sub>LED</sub>=20mA(Per Led). The LED life time could be decreased if operating I<sub>LED</sub> is larger than 20mA.

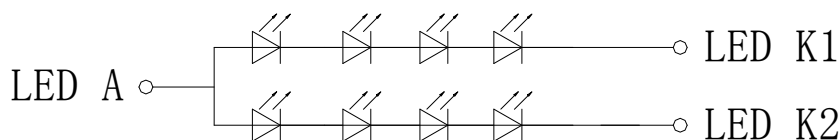



## 5.3 Power On/Off Sequence

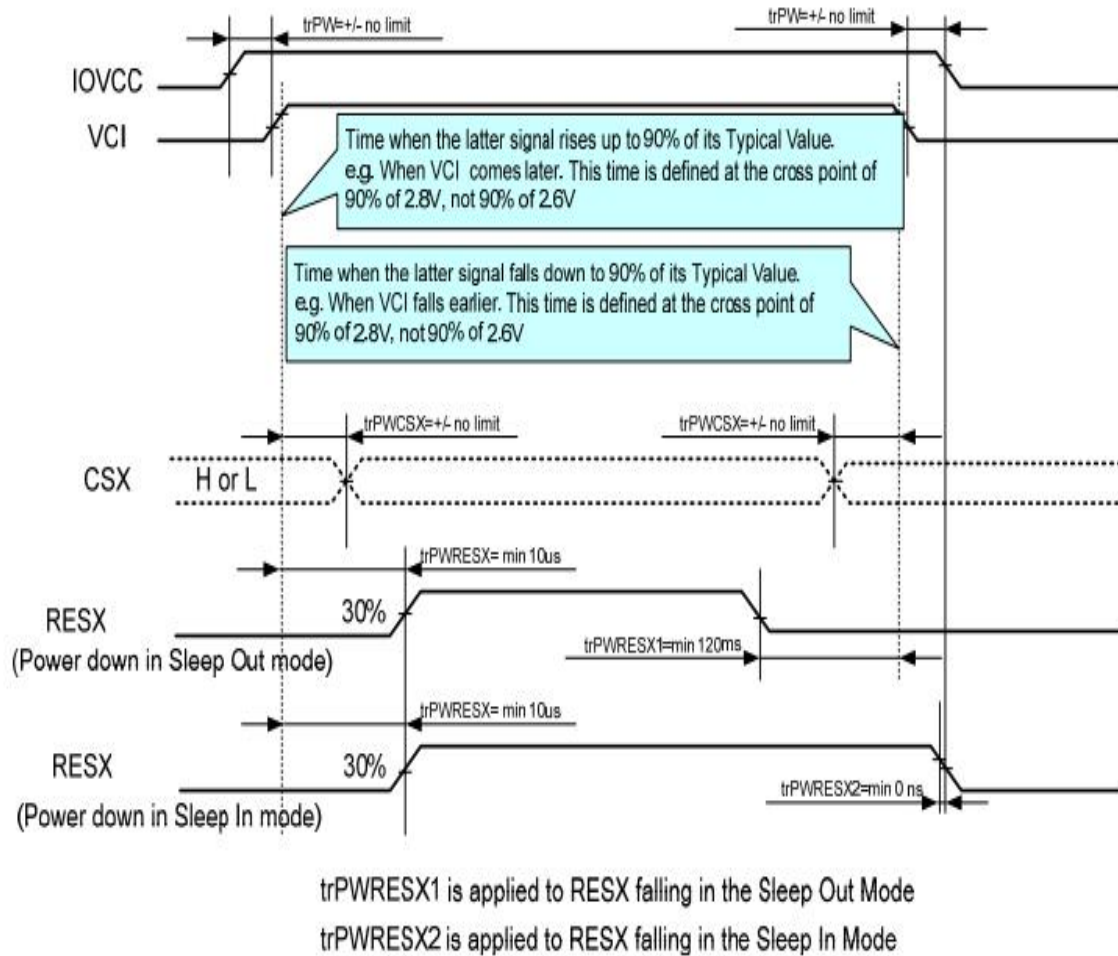

### 5.3.1 Power Off Sequence

The abnormal power off means a situation when e.g. there is removed a battery without the normal power off sequence. There will not be any damages for the display module or the display module will not cause any damages for the host or lines of the interface. At an abnormal power off event, ILI9806E will force the display to blank and will not be any abnormal visible effects with in 1 second on the display and remains blank until "Power On Sequence" powers it up.



## 5.4 Timing Characteristics

### 5.4.1 Timing for 3-Wire SPI Interface

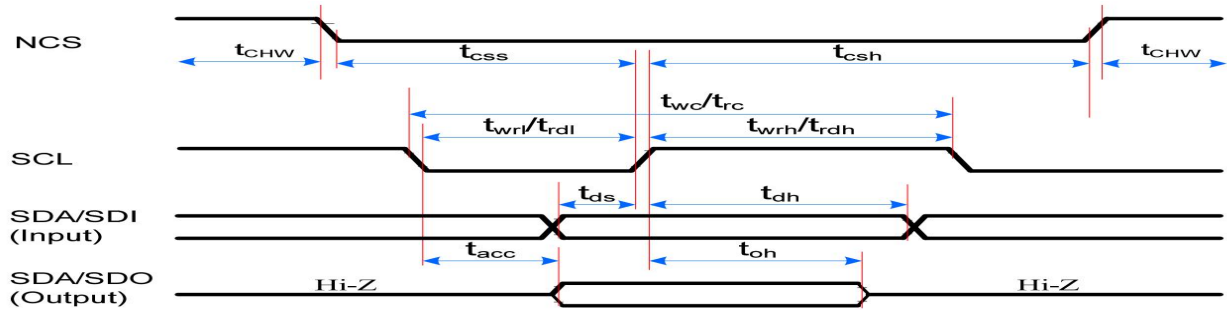

( $T_a=+25^{\circ}\text{C}$ ,  $\text{GND}=0\text{V}$ )

Signal	Symbol	Parameter	min	max	Unit	Description
CSX	t <sub>css</sub>	Chip select time (Write)	15	-	ns	
	t <sub>csh</sub>	Chip select hold time (Read)	15	-	ns	
	t <sub>CHW</sub>	CS "H" pulse width	40	-	ns	
SCL	t <sub>wc</sub>	Serial clock cycle (Write)	30	-	ns	
	t <sub>wrh</sub>	SCL "H" pulse width (Write)	10	-	ns	
	t <sub>wrl</sub>	SCL "L" pulse width (Write)	10	-	ns	
	t <sub>rc</sub>	Serial clock cycle (Read)	150	-	ns	
	t <sub>rdh</sub>	SCL "H" pulse width (Read)	60	-	ns	
SDA/SDO (Output)	t <sub>acc</sub>	Access time (Read)	10	100	ns	For maximum CL=30pF
	t <sub>oh</sub>	Output disable time (Read)	15	100	ns	For minimum CL=8pF
SDA/SDI (Input)	t <sub>ds</sub>	Data setup time (Write)	10	-	ns	
	t <sub>dh</sub>	Data hold time (Write)	10	-	ns	



## 5.5 Timing Diagram

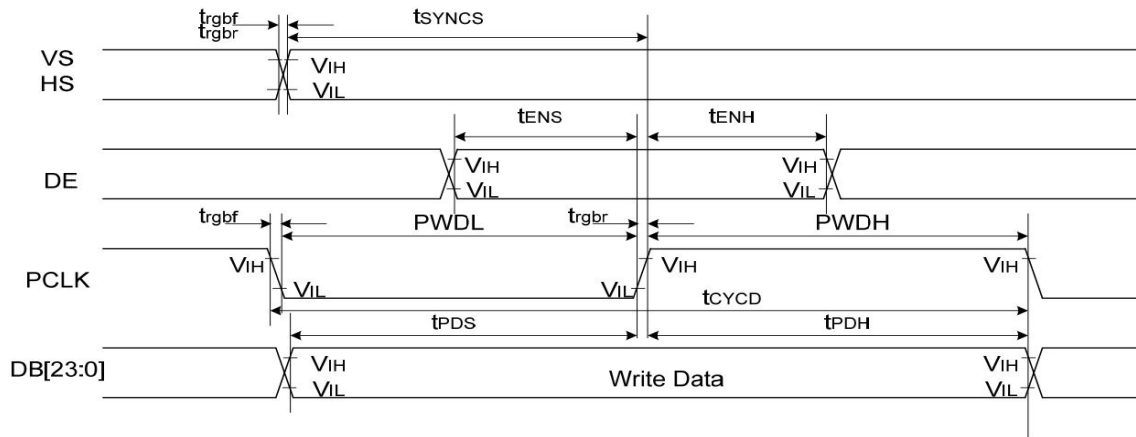

Signal	Symbol	Parameter	min	max	Unit	Description
VS/ HS	$t_{SYNCS}$	VS/HS setup time	5	-	ns	24/18/16-bit bus RGB interface mode
	$t_{SYNCH}$	VS/HS hold time	5	-	ns	
DE	$t_{ENS}$	DE setup time	5	-	ns	
	$t_{ENH}$	DE hold time	5	-	ns	
DB[23:0]	$t_{POS}$	Data setup time	5	-	ns	
	$t_{PDH}$	Data hold time	5	-	ns	
PCLK	PWDH	PCLK high-level period	13	-	ns	
	PWDL	PCLK low-level period	13	-	ns	
	$t_{CYCD}$	PCLK cycle time	28	-	ns	
	$t_{rgbr}, t_{rgbf}$	PCLK,HS,VS rise/fall time	-	15	ns	

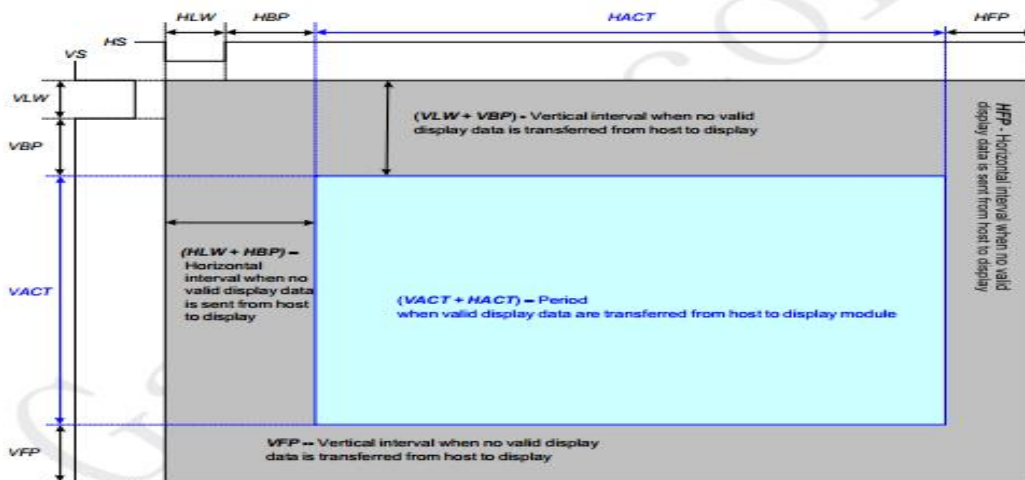

Figure 11 General DPI timing diagram

Parameter	Symbol	Conditio	Min	Typ	Max	Units
Frame Rate	FR		54		6	fps
Horizontal Low Pulse width	HLW		1		-	DOTCL
Horizontal Back Porch	HBP		2		126	DOTCL
Horizontal Address	HACT			48		DOTCL
Horizontal Front Porch	HFP		2		-	DOTCL
Vertical Low Pulse width	VLW		1		126	Line
Vertical Back Porch	VBP		1		126	Line
Vertical Address	VACT				864	Line
Vertical Front Porch	VFP		1		255	Line
Data Clock	DCLK		16.		35.	MHz



## 6. OPTICAL CHARACTERISTICS

Parameter 参数	Symbol 符号	Condition 条件	Min. 最小值	Typ. 典型值	Max. 最大值	Unit 单位	Remark 备注
Contrast Ratio	C/R	$\theta = 0^\circ$	640	800	-	-	Note(4)
NTSC Ratio	S	$\theta = 0^\circ$	50	55	-	%	Note(7)
Luminance	LCM+CTP	$\theta = 0^\circ$	-	300	-	cd/m <sup>2</sup>	Note(5)
Luminance uniformity	U <sub>W</sub>	$\theta = 0^\circ$	-	80	-	%	Note(3)
Response Time	T <sub>R</sub> + T <sub>F</sub>	25 °C	-	25	35	ms	Note(2)
Color Coordination	W <sub>X</sub>	$\theta = 0^\circ$ (Center) Normal viewing angle B/L On	-0.04	TBD	+0.04	NTSC (x,y)	Note(6)
	W <sub>Y</sub>			TBD			
	R <sub>X</sub>			TBD			
	R <sub>Y</sub>			TBD			
	G <sub>X</sub>			TBD			
	G <sub>Y</sub>			TBD			
	B <sub>X</sub>			TBD			
	B <sub>Y</sub>			TBD			
Viewing Angle	$\theta_L$	C/R>10	-	80	-	Degree	Note(1)
	$\theta_R$		-	80	-		
	$\theta_U$		-	80	-		
	$\theta_D$		-	80	-		

Test Conditions:

1. VDD=2.8V, I<sub>F</sub>=40mA (Backlight current), the ambient temperature is +25°C.
2. The test systems refer to Note 8.



**Note1:** Definition of Viewing Angle: The viewing angle range that the CR>10

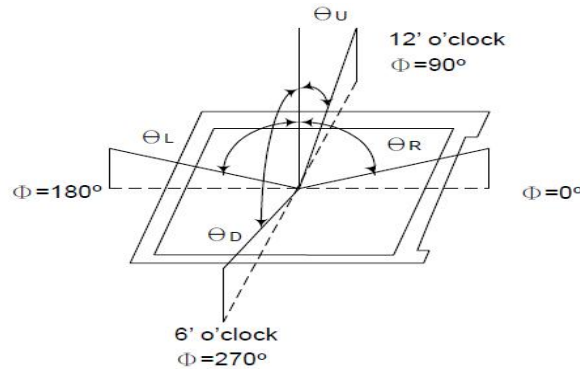

**Note2:** Definition of Response time: Sum of  $T_R$  and  $T_F$

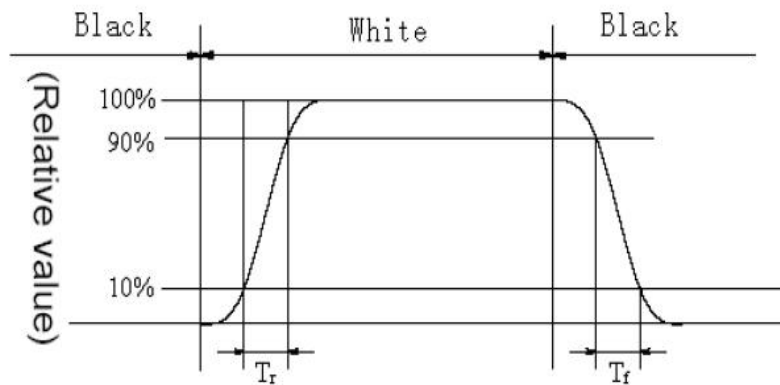

**Note 3:** Definition of Luminance Uniformity: Active area is divided into 9 measuring areas, every measuring point is placed at the center of each measuring area.

$$\text{Luminance Uniformity} = \frac{\text{Min Luminance of white among 9-points}}{\text{Max Luminance of white among 9-points}} \times 100\%$$

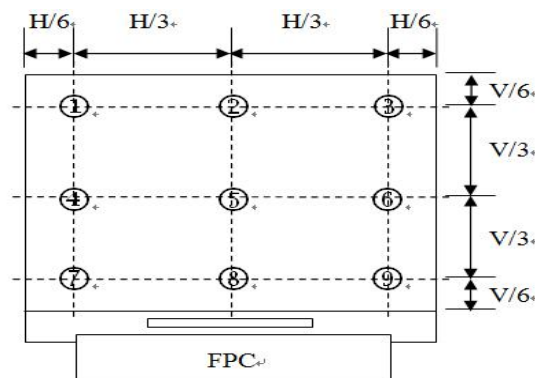

**Note4:** Definition of Contrast Ratio (CR): measured at the center point of panel

$$\text{Contrast ratio (CR)} = \frac{\text{Luminance measured when LCD on the "White" state}}{\text{Luminance measured when LCD on the "Black" state}}$$



**Note 5:** Definition of Luminance: Center Luminance of white is defined as luminance values of 1point average across the LCD surface.

**Note 6:** Definition of Color Chromaticity (CIE 1931)

Color coordinates of white & red, green, blue measured at center point of LCD.

**Note 7:** Definition of NTSC ratio:

$$\text{NTSC ratio} = \frac{\text{Area of RGB triangle}}{\text{Area of NTSC triangle}}$$

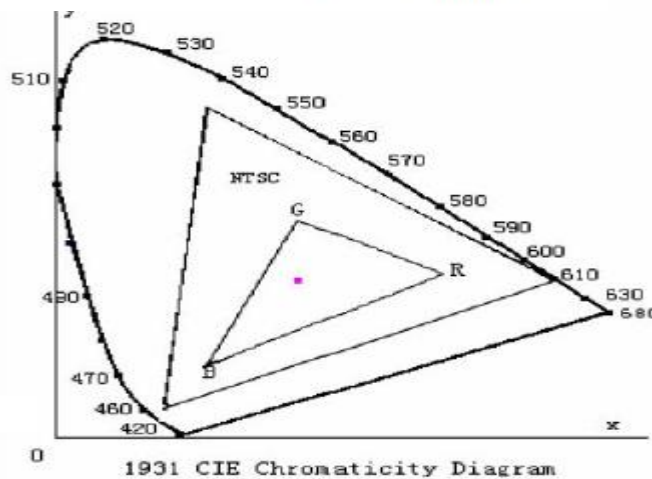

**Note 8:** Definition of measurement system.

optical

The optical characteristics should be measured in dark room. After 5 minutes operation, the optical properties are measured at the center point of the LCD screen.(Response time is measured by Photo detector TOPCON BM-7, Field of view: 1°/Height: 500mm.)

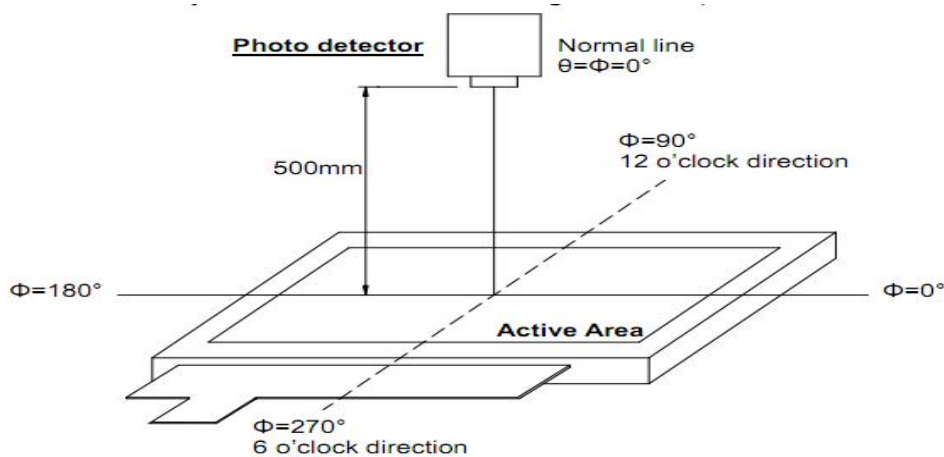



## 7. RELIABILITY

Item 项目	Test Condition 测试条件	Remark 备注
High Temperature Storage	Ta =+80°C / 96Hours	Note1,2,3
Low Temperature Storage	Ta =-30°C / 96Hours	Note1,2,3
High Temperature Operating	Ta =+70°C / 96Hours	Note1,2,3
Low Temperature Operating	Ta =-20°C / 96Hours	Note1,2,3
Temperature Cycle storage Test	-30°C/30min ↔+70°C /30min for 30cycles,Transfer time less than 5min	Note2,3
Thermal humidity storage Test	80°C x 90%RH / 96Hours	Note2,3
Package Vibration Test	Frequency: 10Hz~55Hz,Amplitude:1.5mm, 1 hrs for each direction of X, Y, Z	Note2
Packing shock test	Drop to the ground from 60cm height, 1 corner, 3 edges, 6 surfaces.	Note2
ESD test	Contact: ±4KV Air: ±8KV	ESD

### Inspection after Test:

Note1: Ta is the ambient temperature of samples.

Note 2: In the standard condition, there shall be no practical problem that may affect the display function. After the reliability test, the product only guarantees operation, but doesn't guarantee all the cosmetic specification.

Note 3: Before cosmetic and function tests , the product must have enough recovery time, at least 2 hours at room temperature.



## 8. PACKAGE DRAWING

